

**two-piece, »multifix« series**

Two-piece service units consisting of a reversible diaphragm pressure regulator, independent of inlet pressure, with self-relieving design, combined with a centrifugal separator and a proportional lubricator.

Control range:	0.5 - 10 bar
Max. medium temperature:	60 °C
Max. ambient temperature:	60 °C
Drain valve:	Semi-automatic
Spring bonnet:	POM-brass
Sealant:	NBR
Flow rate measurement:	At P <sub>1</sub> = 10 bar, P <sub>2</sub> = 6.3 bar and pressure drop Δp = 1 bar
Internal air consumption:	Depending on secondary pressure

Service unit, 2-piece with metal bowl and sight glass, metal (zinc-glass-NBR) sight dome								
Art. No.	Type No.	Thread	Max. input pressure bar	Housing	Filter rating μm	Flow rate l/min	Size	DN
133126	CL 45 M-SR-10	G 1	20	Die-cast aluminium	5	12000	4	25

Accessories / spare parts		
Art. No.	Type No.	Description
135858	ZW 45	Mounting bracket with 2 screws
135857	KP 45	Coupler pack for modular assembly of several devices
135859	KSS 45 F-HA	Polycarbonate bowl, Bowl guard with semi-automatic draining
135860	KSS 45 F-A	Polycarbonate bowl, Bowl guard with fully automatic draining
135861	MS 45 FS	Metal bowl with sight glass and semi-automatic draining
135862	MS 45 FS-A	Metal bowl with sight glass and fully automatic draining
135863	KSS 45 NS	Polycarbonate bowl, without drain valve
135864	MS 45 NS	Metal bowl, without drain valve
100362	655.6.900	Automatic drain valve
135855	22.1845.4	Set of wearing parts
100144	6141.6.905	Filter element 5 μm, Cellpor
100392	1233.7.990	Sight dome (polyamide PA)
100393	1233.7.909	Sight dome, metal

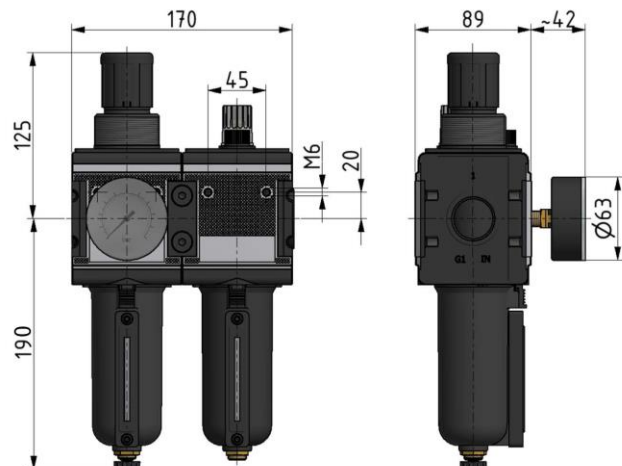

flow characteristic

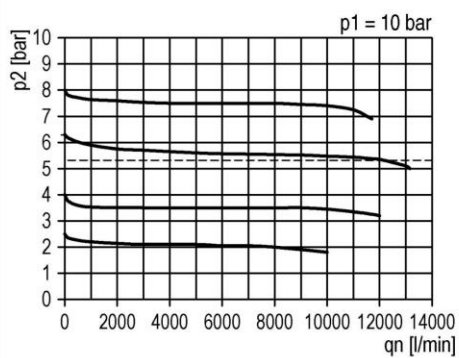

pressure characteristic

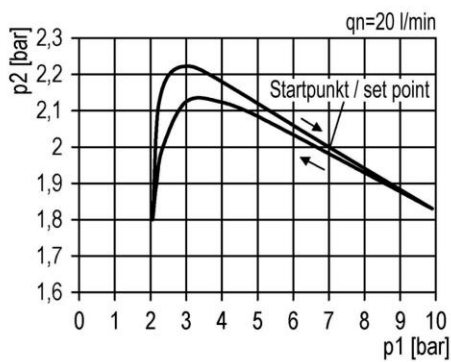

lubricator operating limit

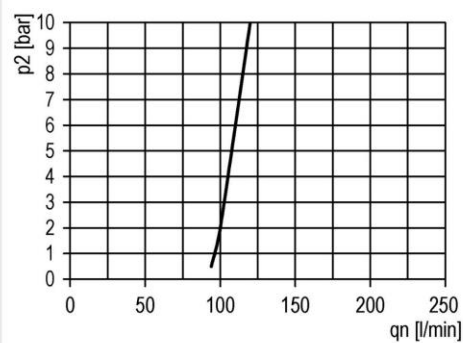

symbol

